

## F9000™ *Inversion Table*

U.S. and foreign patents apply. Other foreign patents pending.

### PRE-ASSEMBLY

**Before you begin:** These instructions will guide you in properly assembling the unit. Please review all the steps before beginning assembly. Carefully adhere to the Assembly Instructions and Owner's Manual to help ensure user safety and product integrity.

### ⚠ WARNING

1. It is your responsibility to familiarize yourself with the proper use of the equipment and the inherent risks of inversion, such as falling on your head or neck, pinching, entrapment or equipment failure.
2. This product is not designed for persons over 6'6" (198 cm) or 300 lbs (136 kg). Structural failure could occur or head/neck may impact floor during inversion. Serious injury or death could result.
3. DO NOT use the equipment without a licensed physician's approval and a review of the medical contraindications, as noted in the Owner's Manual.
4. Failure to assemble and/or use the equipment as directed may void the manufacturer's warranty on this product and could result in injury or death.
5. DO NOT use the inversion table until you have thoroughly and carefully read the Owner's Manual, viewed the Instructional Video, reviewed all other accompanying documents, and inspected the equipment.
6. The steps in the video directly coincide with the steps detailed in these Assembly Instructions.
7. Choose a level surface for assembling and operating the table.
8. Follow each step in sequence. Do not skip ahead.
9. Make sure that all fasteners are secure.
10. PRIOR TO USE, test and inspect the table. Make sure the table rotates smoothly to inverted position and back.

Carefully remove the individual parts from the carton. You should have all of the items listed below. If any items are missing or damaged, contact your retailer or customer service directly (See Pg. 4).

ITEMS FOR ASSEMBLY	ITEM #'s
A-frame base	F71002
Main shaft w/ ankle clamp	F91039
Table frame with mat	F51021
-----	
Hand grips (2) and 1/2" (13mm) hex bolts (6)	F51069 H11202
Two (2) roller hinges	F51064
Two (2) wrenches	F51088



### ASSEMBLY

#### STEP ONE

##### Assemble the A-frame Base (F71002)

- Open the A-frame and make sure that the spreader arms are locked flat. (See Figure 1)

Figure 2

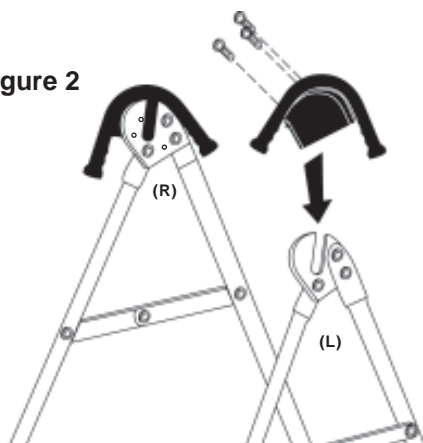
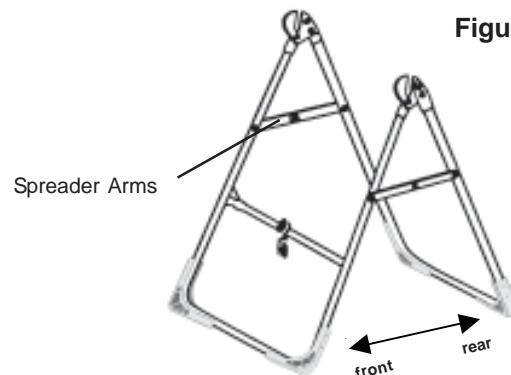

Figure 1



#### STEP TWO

##### Install Hand Grips (F51069) on A-frame Base (F71002)

- Place one of each hand grip (left / right) over the outside edge of the corresponding hinge plate. (See Figure 2)
- Insert three 1/2" (13 mm) hex bolts (H11202) through the hinge plate into each hand grip. Use the wrenches provided to tighten the bolts, being careful not to over tighten.

# ASSEMBLY

## STEP THREE

### Install Roller Hinges (F51064) to Table Frame (F51021)

- For ease of assembly, rest the table frame against the crossbar at the front of the A-frame.
- Open the cam locks on each side of the table frame.
- With the grooved pivot pins facing out, insert the roller hinges into the brackets on each side of the table frame. (See Figure 3) The roller hinges will slide between the cam locks and the brackets. (See Figure 3A)
- Make sure that the roller hinges are in the same hole setting on both sides.
- Push down on the cam lock to secure the hinge. Figure 3B shows the roller hinge engaged correctly (in Setting C).

Refer to the Owner's Manual for an explanation of the hole settings.  
We suggest using Setting C to start.

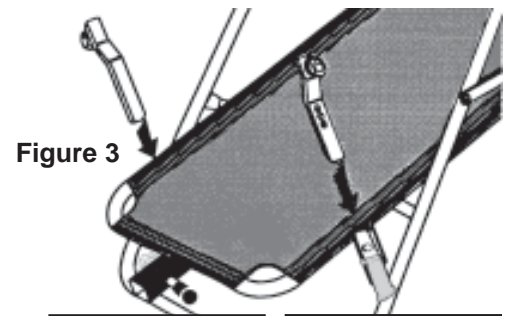

Figure 3

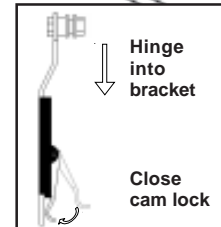

Figure 3A

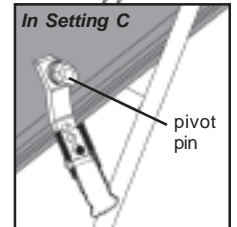

Figure 3B

Figure 4

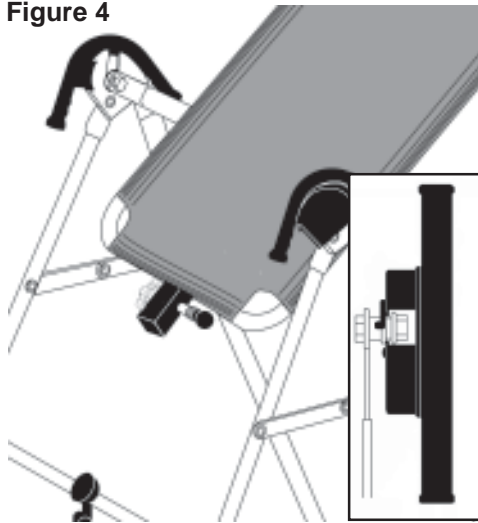

Figure 4A

## STEP FOUR

### Attach the Table Frame (F51021) to the A-frame (F71002)

- Holding each side near the roller hinges, pick up the table frame and stand at the front of the A-frame. Lower each pivot pin into the A-frame hinge plates at the same time. (See Figure 4) Figure 4A shows the correct placement of the pivot pin into the hinge plate.
- Make sure that both pivot pins are seated at the base of the slot in the hinge plate.
- Check to make sure that the self-locking hooks have closed over both pivot pins and that the table rotates smoothly.

### ⚠ WARNING

Failure of the self-locking hooks to close over both pivot pins is indication of improper assembly and if not corrected, could result in serious injury or death.

## STEP FIVE

### Insert the Main Shaft (F91039) into the Table Frame (F51021)

- Loosen the de-rattler knob on the main shaft housing.
- With the height adjustment settings on the main shaft facing up, slide the end of the main shaft into the blue bushing in the main shaft housing. (See Figure 5)
- Pull out the height selector locking pin to allow the main shaft to slide in further. For the purpose of easy assembly, slide the main shaft in all the way and release the pin in the storage setting. (Refer to the Owner's Manual for proper height adjustment before use).
- Tighten the de-rattler knob.

### ⚠ WARNING

Read the Owner's Manual for information on selecting the correct user height setting. Improper settings could result in serious injury or death.

Figure 5

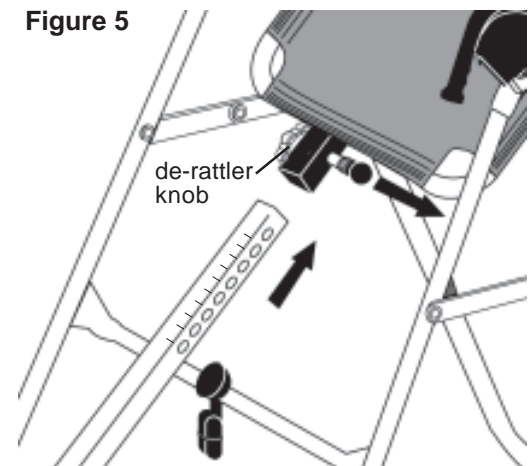

## STEP SIX

### Attach the Tether Strap to Limit the Degree of Rotation

- Unfold the tether strap and snap it into the U-bar on the underside of the table frame. (See Figure 6)
- The tether strap is adjustable to stop the inversion table at any desired angle.

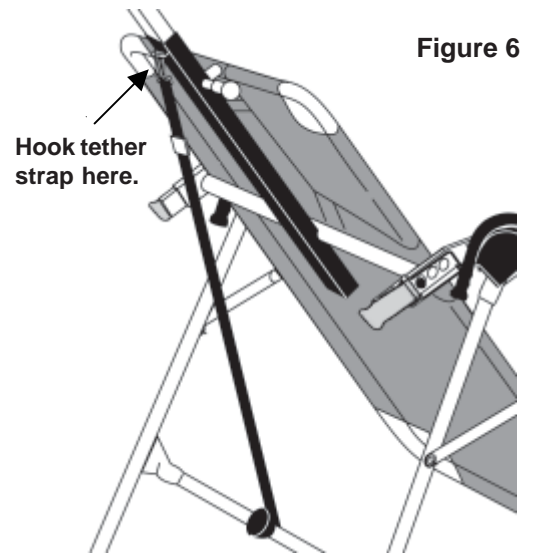

Figure 6

## STEP TEN

### Testing the Assembly

#### PRIOR TO USE:

- Test the table by hand for smooth and steady rotation.
- Ensure all fasteners are secure.

### You have completed the assembly of your Teeter Hang Ups® Inversion Table.

- Read your Owner's Manual thoroughly before using the inversion table. Improper settings could result in serious injury or death.
- For your reference, the table's serial number can be found at the base of the table frame on the back.
- Please complete and mail your warranty card, or submit it on-line at [www.STLIntl.com](http://www.STLIntl.com).



## POST ASSEMBLY ADJUSTMENTS ■ MAINTENANCE ■ STORAGE

### CHANGING THE ROLLER HINGE SETTING

- Stand with your legs on either side of the main shaft.
- Reach under each roller hinge with your index fingers. Use your thumbs to release the locks over the roller hinges. (See Figure 7)
- Lift both sides of the table out of the A-frame at the same time. You may rest the table on the crossbar of the A-frame.
- Unlock the cam locks for each roller hinge. Change the roller hinges to the desired setting (A, B, or C, from most aggressive to least aggressive). (See Figure 8)
- Relock the cam locks. Replace the roller hinges into the hinge plates of the A-frame.



Figure 7

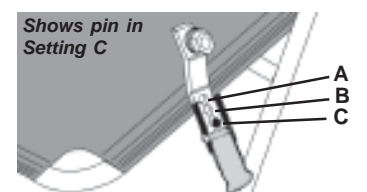
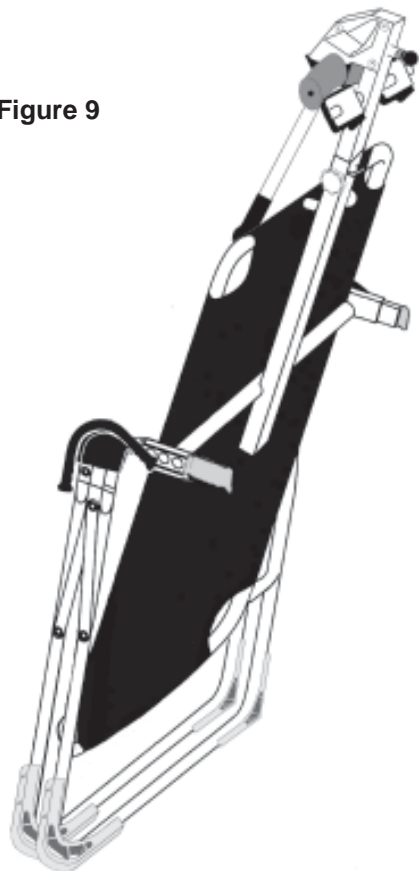

Figure 8

Figure 9



## STORING THE INVERSION TABLE

**IMPORTANT NOTE:** The F9000™ will not fold for storage while in Setting “C” of the roller hinge. You must have the roller hinge set in either the “A” or “B” setting to do so.

- Loosen the de-rattler knob.
- Pull the height selector locking pin and slide the main shaft in all the way to the ankle clamp assembly. Engage the pin in the storage setting.
- Rotate the table *opposite from use* until the table has turned 180 degrees and rests against the cross bar on the A-frame.
- The legs of the A-frame base may then be folded together for compact storage. (See Figure 9). **WARNING: This operation may pinch fingers if not done slowly and carefully.**

## TABLE MAT: REMOVING / CLEANING / TIGHTENING

- You may find it easier to remove the nylon mat while the table is in its storage position.
- Pull up on the plastic tension clips to loosen the adjustment straps.
- Release one corner at a time, then slide the mat off the frame.
- The mat should be washed in cold on gentle cycle. Replace the mat on the table frame while still wet.
- If you feel the nylon mat needs to be tightened, pull the adjustment straps on the back of the mat.

*For additional languages in Spanish, French, Dutch, German, Italian, or Portuguese, please contact customer service.*



Classified as Medical Equipment, part I in accordance with UL 2601-1 and CAN/CSA C22.2: General Requirements for Safety in accordance with Underwriters Laboratories, Inc.

\* any modification to this device will void the UL Classification



For information about the Teeter Hang Ups® 5-year warranty, or if you have any problems assembling the equipment or questions about its use, please contact Customer Service at the appropriate location below:

### USA & Canada:

STL International, Inc.  
9902 162<sup>nd</sup> St. Ct. E., Puyallup, WA 98375  
Toll Free (Phone) 800-847-0143 (Fax) 800-847-0188  
Local (Phone) 253-840-5252 (Fax) 253-840-5757  
(email) Info26@STLIntl.com (web) www.STLIntl.com

### International:

Inversion International, Ltd.  
PO Box: AP 59245, New Providence Island, Bahamas  
(Phone) +1-242-362-1001 (Fax) +1-242-362-1002  
(email) Info@InversionInternational.com (web) www.InversionInternational.com

U.S. and foreign patents apply. Other foreign patents pending.  
Teeter Hang Ups® is a registered trademark of STL International, Inc. and Inversion International, Ltd.  
Specifications subject to change without notice.  
© COPYRIGHT 2004, STL International, Inc.  
International Law Prohibits Any Copying, 05/04-8